

Contract Routing Form

ROUTING: Urgent Rush

printed on: 09/08/2021

Contract between: Speedway Sand & Gravel, Inc.  
and Dept. or Division: Engineering Division  
Name/Phone Number:

Project: Summit Maintenance Facility Improvements 2021

Contract No.: 9055  
Enactment No.: RES-21-00571  
Dollar Amount: 111,534.89

File No.: 66864  
Enactment Date: 09/07/2021

(Please DATE before routing)

Signatures Required	Date Received	Date Signed
City Clerk	9/8/2021	9/8/2021
Director of Civil Rights	9/8/2021	9/9/2021 MG
Risk Manager	9/9/21	9/9/21 mce
Finance Director	9/9/21	9/9/21
City Attorney	9/9/21	9/9/21
Mayor	9/9/2021	

Please return signed Contracts to the City Clerk's Office  
Room 103, City-County Building for filing.

Original + 2 Copies

09/08/2021 13:43:59 enjls - Corey Stelljes 266-6518

PROJECT

CONTRACTOR

AMOUNT OF BID

CONTRACT NO. 9055  
SUMMIT MAINTENANCE FACILITY IMPROVEMENTS 2021

SPEEDWAY SAND & GRAVEL, INC.

\$ 111,534.89

Acct. No. 13474-51-130: 54250 (91336)  
Contingency 8%±

\$ 111,534.89  
8,925.11

GRAND TOTAL

\$ 120,460.00



**Wisconsin**  
State Based Systems

**Demographics**

**Company Name:** Fidelity and Deposit Company of Maryland  
**SBS Company Number:** 54219634  
**Domicile Type:** Foreign  
**NAIC Group Number:** 212 - ZURICH INS GRP  
**Merger Flag:** No

**NAIC CoCode:** 39306  
**State of Domicile:** Illinois  
**Organization Type:** Stock

**Short Name:**  
**FEIN:** 13-3046577  
**Country of Domicile:** United States  
**Date of Incorporation:** 03/18/1969

**Address**

Business Address	Mailing Address	Statutory Home Office Address	Main Administrative Office Address
1299 Zurich Way Schaumburg, IL 60196-1056 United States	1299 Zurich Way Schaumburg, IL 60196-1056 United States	1299 Zurich Way Schaumburg, IL 60196-1056 United States	1299 Zurich Way Schaumburg, IL 60196-1056 United States

**Phone, Email, Website**

Phone	Email	Website								
<table border="1"> <thead> <tr> <th>Type</th> <th>Number</th> </tr> </thead> <tbody> <tr> <td>Toll Free Phone</td> <td>(800) 382-2150</td> </tr> <tr> <td>Business Primary Phone</td> <td>(847) 413-5048</td> </tr> <tr> <td>Business Primary Phone</td> <td>(847) 605-6000</td> </tr> </tbody> </table>	Type	Number	Toll Free Phone	(800) 382-2150	Business Primary Phone	(847) 413-5048	Business Primary Phone	(847) 605-6000	No results found.	No results found.
Type	Number									
Toll Free Phone	(800) 382-2150									
Business Primary Phone	(847) 413-5048									
Business Primary Phone	(847) 605-6000									

**Company Type**

**Company Type:** Property and Casualty  
**Status:** Active  
**Effective Date:** 12/31/2018  
**Issue Date:** 01/01/1982  
**Articles of Incorporation Received:** No

**Status Reason:**  
**Legacy State ID:** 111700  
**Approval Date:**  
**Article No:**

**Status Date:** 01/01/1982  
**Expiration Date:**  
**File Date:**  
**COA Number:**

**Appointments**

Show  entries

Showing 191 to 200 of 1329 entries

Licensee Name	License Number	NPN	License Type	Line of Authority	Appointment Date	Effective Date	Expiration Date
JOSEPH AGNELLO	255201	255201	Intermediary (Agent) Individual	Casualty	07/12/2019	01/07/2021	03/15/2022
JOSEPH AGNELLO	255201	255201	Intermediary (Agent) Individual	Property	07/12/2019	01/07/2021	03/15/2022
NICOLE STILLINGS	6966174	6966174	Intermediary (Agent) Individual	Casualty	04/22/2019	01/07/2021	03/15/2022
NICOLE STILLINGS	6966174	6966174	Intermediary (Agent) Individual	Property	04/22/2019	01/07/2021	03/15/2022
THOMAS BRASS	6507620	6507620	Intermediary (Agent) Individual	Casualty	05/14/2019	01/07/2021	03/15/2022
THOMAS BRASS	6507620	6507620	Intermediary (Agent) Individual	Property	05/14/2019	01/07/2021	03/15/2022
GAYNOR NEUMAIER	8422697	8422697	Intermediary (Agent) Individual	Property	08/15/2019	01/07/2021	03/15/2022
GAYNOR NEUMAIER	8422697	8422697	Intermediary (Agent) Individual	Casualty	08/15/2019	01/07/2021	03/15/2022
JO REINKE	6523540	6523540	Intermediary (Agent) Individual	Property	06/24/2019	01/07/2021	03/15/2022
JO REINKE	6523540	6523540	Intermediary (Agent) Individual	Casualty	06/24/2019	01/07/2021	03/15/2022

**Line Of Business**

Line of Business	Citation Type	Effective Date
Aircraft	Aircraft	01/01/1982
Automobile	Automobile	01/01/1982
Credit Insurance	Credit Insurance	01/01/1982
Fidelity Insurance	Fidelity Insurance	01/01/1982
Fire, Inland Marine and Other Property Insurance	Fire, Inland Marine and Other Property Insurance	01/01/1982
Liability and Incidental Medical Expense Insurance (other than automobile)	Liability and Incidental Medical Expense Insurance (other than automobile)	01/01/1982
Miscellaneous	Miscellaneous	01/01/1982
Ocean Marine Insurance	Ocean Marine Insurance	01/01/1982
Surety Insurance	Surety Insurance	01/01/1982
Workers Compensation Insurance	Workers Compensation Insurance	01/01/1982

**Contact**

© 2021 National Association of Insurance Commissioners. All rights reserved.

Contact Type	Preferred Name	Name	E-mail	Phone	Address
Registered Agent for Service of Process		.			Other CORPORATION SERVICE COMPANY 8040 EXCELSIOR DR STE 400 MADISON, WI United States County 53717

### Company Merger

No results found.

### Name Change History

Previous Name	New Name	Effective Date
	Fidelity and Deposit Company of Maryland	

\$111,534.89  
FILE COPY

BID OF SPEEDWAY SAND & GRAVEL, INC.

2021

PROPOSAL, CONTRACT, BOND AND SPECIFICATIONS

FOR

SUMMIT MAINTENANCE FACILITY IMPROVEMENTS 2021

CONTRACT NO. 9055

MUNIS NO. 13474-51-130

IN

MADISON, DANE COUNTY, WISCONSIN

AWARDED BY THE COMMON COUNCIL  
MADISON, WISCONSIN ON AUGUST 31, 2021

CITY ENGINEERING DIVISION  
1600 EMIL STREET  
MADISON, WISCONSIN 53713

<https://bidexpress.com/login>

**SUMMIT MAINTENANCE FACILITY IMPROVEMENTS 2021  
CONTRACT NO. 9055**

**INDEX**

SECTION A: ADVERTISEMENT FOR BIDS AND INSTRUCTIONS TO BIDDERS .....A-1  
SECTION B: PROPOSAL SECTION..... B-1  
SECTION C: SMALL BUSINESS ENTERPRISE ..... C-1  
SECTION D: SPECIAL PROVISIONS..... D-1  
SECTION E: BIDDER’S ACKNOWLEDGEMENT ..... E-1  
SECTION F: BEST VALUE CONTRACTING ..... F-1  
SECTION G: BID BOND..... G-1  
SECTION H: AGREEMENT..... H-1  
SECTION I: PAYMENT AND PERFORMANCE BOND ..... I-1

This Proposal, and Agreement have  
been prepared by:

**CITY PARKS DIVISION  
CITY OF MADISON  
MADISON, DANE COUNTY, WISCONSIN**

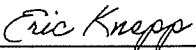
  
Eric Knepp, Parks Superintendent

RFP: EMK

## SECTION A: ADVERTISEMENT FOR BIDS AND INSTRUCTIONS TO BIDDERS

### REQUEST FOR BID FOR PUBLIC WORKS CONSTRUCTION CITY OF MADISON, WISCONSIN

#### A BEST VALUE CONTRACTING MUNICIPALITY

PROJECT NAME:	SUMMIT MAINTENANCE FACILITY IMPROVEMENTS 2021
CONTRACT NO.:	9055
SBE GOAL	3%
BID BOND	5%
SBE PRE BID MEETING	See Pre Bid Meeting info below
PREQUALIFICATION APPLICATION DUE (2:00 P.M.)	7/29/21
BID SUBMISSION (2:00 P.M.)	8/5/21
BID OPEN (2:30 P.M.)	8/5/21
PUBLISHED IN WSJ	7/22/21 & 7/29/21

SBE PRE BID MEETING: Small Business Enterprise Pre-Bid Meetings are not being held in person at this time. Contractors can schedule one-on-one phone calls with Juan Pablo Torres Meza in Affirmative Action to count towards good faith efforts. Juan Pablo can be reached at 608-261-9162 or by email, [jtorresmeza@cityofmdison.com](mailto:jtorresmeza@cityofmdison.com).

PREQUALIFICATION APPLICATION: Forms are available on our website, [www.cityofmadison.com/business/pw/forms.cfm](http://www.cityofmadison.com/business/pw/forms.cfm). If not currently prequalified in the categories listed in Section A, an amendment to your Prequalification will need to be submitted prior to the same due date. Postmark is not applicable.

BIDS TO BE SUBMITTED: by hand to 1600 EMIL ST., MADISON, WI 53713 or online at [www.bidexpress.com](http://www.bidexpress.com).

THE BID OPENING is at 1600 EMIL ST., MADISON, WI 53713.

The process for submission of bids has not changed. Bids may be submitted on line through Bid Express or in person at 1600 Emil St. Please note that the doors at 1600 Emil St. are locked, but there is a sign with phone numbers on the door. Please call one of the numbers and staff will come to the door to get your bid. Until further notice, the bid openings will be closed to the public to support the guidance of social distancing as the City responds to responsively to COVID-19 impacts to services. The bids will be posted on line after the bid opening. If you have any questions, please call Alane Boutelle at 608-267-1197, or John Fahrney at 608-266-9091.

#### STANDARD SPECIFICATIONS

The City of Madison's Standard Specifications for Public Works Construction - 2021 Edition, as supplemented and amended from time to time, forms a part of these contract documents as if attached hereto.

These standard specifications are available on the City of Madison Public Works website, [www.cityofmadison.com/Business/PW/specs.cfm](http://www.cityofmadison.com/Business/PW/specs.cfm).

The Contractor shall review these Specifications prior to preparation of proposals for the work to be done under this contract, with specific attention to Article 102, "BIDDING REQUIREMENTS AND CONDITIONS" and Article 103, "AWARD AND EXECUTION OF THE CONTRACT." For the convenience of the bidder, below are highlights of three subsections of the specifications.

## SECTION 102.1: PRE-QUALIFICATION OF BIDDERS

In accordance with Wisconsin State Statutes 66.0901 (2) and (3), all bidders must submit to the Board of Public Works proof of responsibility on forms furnished by the City. The City requires that all bidders be qualified on a biennial basis.

Bidders must present satisfactory evidence that they have been regularly engaged in the type of work specified herein and they are fully prepared with necessary capital, materials, machinery and supervisory personnel to conduct the work to be contracted for to the satisfaction of the City. All bidders must be pre-qualified by the Board of Public Works for the type of construction on which they are bidding prior to the opening of the bid.

In accordance with Section 39.02(9)(a). of the General Ordinances, all bidders shall submit in writing to the Affirmative Action Division Manager of the City of Madison, a Certificate of Compliance or an Affirmative Action Plan at the same time or prior to the submission of the proof of responsibility forms.

The bidder shall be disqualified if the bidder fails to or refuses to, prior to opening of the bid, submit a Certificate of compliance, Affirmative Action Plan or Affirmative Action Data Update, as applicable, as defined by Section 39.02 of the General Ordinances (entitled Affirmative Action) and as required by Section 102.11 of the Standard Specifications.

## SECTION 102.4 PROPOSAL

No bid will be accepted that does not contain an adequate or reasonable price for each and every item named in the Schedule of Unit Prices.

A lump sum bid for the work in accordance with the plans and specifications is required. The lump sum bid must be the same as the total amounts bid for the various items and it shall be inserted in the space provided.

All papers bound with or attached to the proposal form are considered a part thereof and must not be detached or altered when the proposal is submitted. The plans, specifications and other documents designated in the proposal form will be considered a part of the proposal whether attached or not.

A proposal submitted by an individual shall be signed by the bidder or by a duly authorized agent. A proposal submitted by a partnership shall be signed by a member/partner or by a duly authorized agent thereof. A proposal submitted by a corporation shall be signed by an authorized officer or duly authorized registered agent of such corporation, and the proposal shall show the name of the State under the laws of which such corporation was chartered. The required signatures shall in all cases appear in the space provided thereof on the proposal.

Each proposal shall be placed, together with the proposal guaranty, in a sealed envelope, so marked as to indicate name of project, the contract number or option to which it applies, and the name and address of the Contractor or submitted electronically through Bid Express ([www.bidexpress.com](http://www.bidexpress.com)). Proposals will be accepted at the location, the time and the date designated in the advertisement. Proposals received after the time and date designated will be returned to the bidder unopened.

## SECTION 102.5: BID DEPOSIT (PROPOSAL GUARANTY)

All bids, sealed or electronic, must be accompanied with a Bid Bond (City of Madison form) equal to at least 5% of the bid or a Certificate of Annual/Biennial Bid Bond or certified check, payable to the City Treasurer. Bid deposit of the successful bidders shall be returned within forty-eight (48) hours following execution of the contract and bond as required.

## MINOR DISCREPENCIES

Bidder is responsible for submitting all forms necessary for the City to determine compliance with State and City bidding requirements. Notwithstanding any language to the contrary contained herein, the City



may exercise its discretion to allow bidders to correct or supplement submissions after bid opening, if the minor discrepancy, bid irregularity or omission is insignificant and not one related to price, quality, quantity, time of completion or performance of the contract.

**Bidders for this Contract(s) must be Pre-Qualified for at least one of the following type(s) of construction denoted by an**

Building Demolition

- 101  Asbestos Removal  
120  House Mover

- 110  Building Demolition

Street, Utility and Site Construction

- 201  Asphalt Paving  
205  Blasting  
210  Boring/Pipe Jacking  
215  Concrete Paving  
220  Con. Sidewalk/Curb & Gutter/Misc. Flat Work  
221  Concrete Bases and Other Concrete Work  
222  Concrete Removal  
225  Dredging  
230  Fencing  
235  Fiber Optic Cable/Conduit Installation  
240  Grading and Earthwork  
241  Horizontal Saw Cutting of Sidewalk  
242  Hydro Excavating  
243  Infrared Seamless Patching  
245  Landscaping, Maintenance  
246  Ecological Restoration  
250  Landscaping, Site and Street  
251  Parking Ramp Maintenance  
252  Pavement Marking  
255  Pavement Sealcoating and Crack Sealing  
260  Petroleum Above/Below Ground Storage Tank Removal/Installation  
262  Playground Installer

- 265  Retaining Walls, Precast Modular Units  
270  Retaining Walls, Reinforced Concrete  
275  Sanitary, Storm Sewer and Water Main Construction  
276  Sawcutting  
280  Sewer Lateral Drain Cleaning/Internal TV Insp.  
285  Sewer Lining  
290  Sewer Pipe Bursting  
295  Soil Borings  
300  Soil Nailing  
305  Storm & Sanitary Sewer Laterals & Water Svc.  
310  Street Construction  
315  Street Lighting  
318  Tennis Court Resurfacing  
320  Traffic Signals  
325  Traffic Signing & Marking  
332  Tree pruning/removal  
333  Tree, pesticide treatment of  
335  Trucking  
340  Utility Transmission Lines including Natural Gas, Electrical & Communications  
399  Other \_\_\_\_\_

Bridge Construction

- 501  Bridge Construction and/or Repair

Building Construction

- 401  Floor Covering (Including carpet, ceramic tile installation, rubber, VCT)  
402  Building Automation Systems  
403  Concrete  
404  Doors and Windows  
405  Electrical - Power, Lighting & Communications  
410  Elevator - Lifts  
412  Fire Suppression  
413  Furnishings - Furniture and Window Treatments  
415  General Building Construction, Equal or Less than \$250,000  
420  General Building Construction, \$250,000 to \$1,500,000  
425  General Building Construction, Over \$1,500,000  
428  Glass and/or Glazing  
429  Hazardous Material Removal  
430  Heating, Ventilating and Air Conditioning (HVAC)  
433  Insulation - Thermal  
435  Masonry/Tuck pointing

- 437  Metals  
440  Painting and Wallcovering  
445  Plumbing  
450  Pump Repair  
455  Pump Systems  
460  Roofing and Moisture Protection  
464  Tower Crane Operator  
461  Solar Photovoltaic/Hot Water Systems  
465  Soil/Groundwater Remediation  
466  Warning Sirens  
470  Water Supply Elevated Tanks  
475  Water Supply Wells  
480  Wood, Plastics & Composites - Structural & Architectural  
499  Other \_\_\_\_\_

State of Wisconsin Certifications

- 1  Class 5 Blaster - Blasting Operations and Activities 2500 feet and closer to inhabited buildings for quarries, open pits and road cuts.  
2  Class 6 Blaster - Blasting Operations and Activities 2500 feet and closer to inhabited buildings for trenches, site excavations, basements, underwater demolition, underground excavations, or structures 15 feet or less in height.  
3  Class 7 Blaster - Blasting Operations and Activities for structures greater than 15' in height, bridges, towers, and any of the objects or purposes listed as "Class 5 Blaster or Class 6 Blaster".  
4  Petroleum Above/Below Ground Storage Tank Removal and Installation (Attach copies of State Certifications.)  
5  Hazardous Material Removal (Contractor to be certified for asbestos and lead abatement per the Wisconsin Department of Health Services, Asbestos and Lead Section (A&LS).) See the following link for application: [www.dhs.wisconsin.gov/Asbestos/Cert](http://www.dhs.wisconsin.gov/Asbestos/Cert). State of Wisconsin Performance of Asbestos Abatement Certificate must be attached.  
6  Certification number as a Certified Arborist or Certified Tree Worker as administered by the International Society of Arboriculture  
7  Pesticide application (Certification for Commercial Applicator For Hire with the certification in the category of turf and landscape (3.0) and possess a current license issued by the DATCP)  
8  State of Wisconsin Master Plumbers License.

## SECTION B: PROPOSAL

Please refer to the  
Bid Express Website  
at <https://bidexpress.com>  
look up contract number  
and go to  
Section B: Proposal Page

You can access all City of Madison bid solicitations for FREE at [www.bidexpress.com](http://www.bidexpress.com)

Click on the "Register for Free" button and follow the instructions to register your company and yourself. You will be asked for a payment subscription preference, since you may wish to bid online someday. Simply choose the method to pay on a 'per bid' basis. This requires no payment until / unless you actually bid online. You can also choose the monthly subscription plan at this time. You will, however, be asked to provide payment information. Remember, you can change your preference at anytime. You will then be able to complete your free registration and have full access to the site. Your free access does not require completion of the 'Digital ID' process, so you will have instant access for viewing and downloading. To be prepared in case you ever do wish to bid online, you may wish to establish your digital ID also, since you cannot bid without a Digital ID.

If you have any problems with the free registration process, you can call the bidexpress help team, toll free at 1-888-352-2439 (option 1, option1).

## SECTION C: SMALL BUSINESS ENTERPRISE

### Instructions to Bidders City of Madison SBE Program Information

#### 2 Small Business Enterprise (SBE) Program Information

##### 2.1 Policy and Goal

The City of Madison reaffirms its policy of nondiscrimination in the conduct of City business by maintaining a procurement process which remains open to all who have the potential and ability to sell goods and services to the City. It is the policy of the City of Madison to allow Small Business Enterprises (SBE) maximum feasible opportunity to participate in City of Madison contracting. The bidder acknowledges that its bid has been submitted in accordance with the SBE program and is for the public's protection and welfare.

Please refer to the "ADVERTISEMENT FOR BIDS" for the goal for the utilization of SBEs on this project. SBEs may participate as subcontractors, vendors and/or suppliers, which provide a commercially useful function. The dollar value for SBE suppliers or 'materials only' vendors shall be discounted to 60% for purposes of meeting SBE goals.

A bidder which achieves or exceeds the SBE goal will be in compliance with the SBE requirements of this project. In the event that the bidder is unable to achieve the SBE goal, the bidder must demonstrate that a good faith effort to do so was made. Failure to either achieve the goal or demonstrate a good faith effort to do so will be grounds for the bidder being deemed a non-responsible contractor ineligible for award of this contract.

A bidder may count towards its attainment of the SBE goal only those expenditures to SBEs that perform a commercially useful function. For purposes of evaluating a bidder's responsiveness to the attainment of the SBE goal, the contract participation by an SBE is based on the percentage of the total base bid proposed by the Contractor. The total base bid price is inclusive of all addenda.

Work performed by an SBE firm in a particular transaction can be counted toward the goal only if it involves a commercially useful function. That is, in light of industry practices and other relevant considerations, does the SBE firm have a necessary and useful role in the transaction, of a kind for which there is a market outside the context of the SBE Program, or is the firm's role a superfluous step added in an attempt to obtain credit towards goals? If, in the judgment of the Affirmative Action Division, the SBE firm will not perform a commercially useful function in the transaction, no credit towards goals will be awarded.

The question of whether a firm is performing a commercially useful function is completely separate from the question of whether the firm is an eligible SBE. A firm is eligible if it meets the definitional criteria and ownership and control requirements, as set forth in the City of Madison's SBE Program.

If the City of Madison determines that the SBE firm is performing a commercially useful function, then the City of Madison must then decide what that function is. If the commercially useful function is that of an SBE vendor / supplier that regularly transacts business with the respective product, then the City of Madison will count 60% of the value of the product supplied toward SBE goals.

To be counted, the SBE vendor / supplier must be engaged in selling the product in question to the public. This is important in distinguishing an SBE vendor / supplier, which has a regular trade with a variety of customers, from a firm which performs supplier-like functions on an ad hoc basis or for only one or two contractors with whom it has a special relationship.

A supplier of bulk goods may qualify as an eligible SBE vendor / supplier if it either maintains an inventory or owns or operates distribution equipment. With respect to the distribution equipment; e.g., a fleet of trucks, the term "operates" is intended to cover a situation in which the supplier leases the equipment on a regular basis for its entire business. It is not intended to cover a situation in which the firm simply provides drivers for trucks owned or leased by another party; e.g., a prime contractor, or leases such a party's trucks on an ad hoc basis for a specific job.

If the commercially useful function being performed is not that of a qualified SBE vendor / supplier, but rather that of delivery of products, obtaining bonding or insurance, procurement of personnel, acting as a broker or manufacturer's representative in the procurement of supplies, facilities, or materials, etc., only the fees or commissions will apply towards the goal.

For example, a business that simply transfers title of a product from manufacturer to ultimate purchaser; e. g., a sales representative who re-invoices a steel product from the steel company to the Contractor, or a firm that puts a product into a container for delivery would not be considered a qualified SBE vendor / supplier. The Contractor would not receive credit based on a percentage of the cost of the product for working with such firms.

Concerning the use of services that help the Contractor obtain needed supplies, personnel, materials or equipment to perform a contract: only the fee received by the service provider will be counted toward the goal. For example, use of a SBE sales representative or distributor for a steel company, if performing a commercially useful function at all, would entitle the Contractor receiving the steel to count only the fee paid to the representative or distributor toward the goal. This provision would also govern fees for professional and other services obtained expressly and solely to perform work relating to a specific contract.

Concerning transportation or delivery services: if an SBE trucking company picks up a product from a manufacturer or a qualified vendor / supplier and delivers the product to the Contractor, the commercially useful function it is performing is not that of a supplier, but simply that of a transporter of goods. Unless the trucking company is itself the manufacturer or a qualified vendor / supplier in the product, credit cannot be given based on a percentage of the cost of the product. Rather, credit would be allowed for the cost of the transportation service.

The City is aware that the rule's language does not explicitly mention every kind of business that may contribute work on this project. In administering these programs, the City would, on a case-by-case basis, determine the appropriate counting formula to apply in a particular situation.

## **2.2 Contract Compliance**

Questions concerning the SBE Program shall be directed to the Contract Compliance Officer of the City of Madison Department of Civil Rights, Affirmative Action Division, 210 Martin Luther King, Jr. Blvd., Room 523, Madison, WI 53703; telephone (608) 266-4910.

## 2.3 Certification of SBE by City of Madison

The Affirmative Action Division maintains a directory of SBEs which are currently certified as such by the City of Madison. Contact the Contract Compliance Officer as indicated in Section 2.2 to receive a copy of the SBE Directory or you may access the SBE Directory online at [www.cityofmadison.com/civil-rights/contract-compliance/targeted-business-enterprise-programs/targeted-business-enterprise](http://www.cityofmadison.com/civil-rights/contract-compliance/targeted-business-enterprise-programs/targeted-business-enterprise).

All contractors, subcontractors, vendors and suppliers seeking SBE status must complete and submit the **Targeted Business Certification Application** to the City of Madison Affirmative Action Division by the time and date established for receipt of bids. A copy of the Targeted Business Certification Application is available by contacting the Contract Compliance Officer at the address and telephone indicated in Section 2.2 or you may access the Targeted Business Certification Application online at [www.cityofmadison.com/civil-rights/contract-compliance/targeted-business-enterprise-programs/targeted-business-enterprise](http://www.cityofmadison.com/civil-rights/contract-compliance/targeted-business-enterprise-programs/targeted-business-enterprise). Submittal of the Targeted Business Certification Application by the time specified does not guarantee that the applicant will be certified as a SBE eligible to be utilized towards meeting the SBE goal for this project.

## 2.4 Small Business Enterprise Compliance Report

### 2.4.1 Good Faith Efforts

Bidders shall take all necessary affirmative steps to assure that SBEs are utilized when possible and that the established SBE goal for this project is achieved. A contractor who self performs a portion of the work, and is pre-qualified to perform that category of work, may subcontract that portion of the work, but shall not be required to do so. When a bidder is unable to achieve the established SBE goal, the bidder must demonstrate that a good faith effort to do so was made. Such a good faith effort should include the following:

- 2.4.1.1 Attendance at the pre-bid meeting.
- 2.4.1.2 Using the City of Madison's directory of certified SBEs to identify SBEs from which to solicit bids.
- 2.4.1.3 Assuring that SBEs are solicited whenever they are potential sources.
- 2.4.1.4 Referring prospective SBEs to the City of Madison Affirmative Action Division for certification.
- 2.4.1.5 Dividing total project requirements into smaller tasks and/or quantities, where economically feasible, to permit maximum feasible SBE participation.
- 2.4.1.6 Establishing delivery schedules, where requirements permit, which will encourage participation by SBEs.
- 2.4.1.7 Providing SBEs with specific information regarding the work to be performed.
- 2.4.1.8 Contacting SBEs in advance of the deadline to allow such businesses sufficient time to prepare a bid.
- 2.4.1.9 Utilizing the bid of a qualified and competent SBE when the bid of such a business is deemed reasonable (i.e. 5% above the lowest bidder), although not necessarily low.
- 2.4.1.10 Contacting SBEs which submit a bid, to inquire about the details of the bid and confirm that the scope of the work was interpreted as intended.
- 2.4.1.11 Completion of Cover Page (page C-6), Summary Sheet (page C-7) and SBE Contact Reports (pages C-8 and C9) if applicable.

## 2.4.2 Reporting SBE Utilization and Good Faith Efforts

The Small Business Enterprise Compliance Report is to be submitted by the bidder with the bid. This report is due by the specified bid closing time and date. Bids submitted without a completed SBE Compliance Report as outlined below may be deemed non-responsible and the bidder ineligible for award of this contract. Notwithstanding any language to the contrary contained herein, the City may exercise its discretion to allow bidders to correct or supplement submissions after bid opening, if the minor discrepancy, bid irregularity or omission is insignificant and not one related to price, quality, quantity, time of completion, performance of the contract, or percentage of SBE utilization.

2.4.2.1 If the Bidder meets or exceeds the goal established for SBE utilization, the Small Business Enterprise Compliance Report shall consist of the following:

- 2.4.2.1.1 **Cover Page**, Page C-6; and
- 2.4.2.1.2 **Summary Sheet**, C-7.

2.4.2.2 If the bidder does not meet the goal established for SBE utilization, the Small Business Enterprise Compliance Report shall consist of the following:

- 2.4.2.2.1 **Cover Page**, Page C-6;
- 2.4.2.2.2 **Summary Sheet**, C-7; and
- 2.4.2.2.3 **SBE Contact Report**, C-8 and C-9. (A separate Contact Report must be completed for each applicable SBE which is not utilized.)

## 2.5 Appeal Procedure

A bidder which does not achieve the established goal and is found non-responsible for failure to demonstrate a good faith effort to achieve such goal and subsequently denied eligibility for award of contract may appeal that decision to the Small Business Enterprises Appeals Committee. All appeals shall be made in writing, and shall be delivered to and received by the City Engineer no later than 4:30 PM on the third business day following the bidder's receipt of the written notification of ineligibility by the Affirmative Action Division Manager. Postmark not acceptable. The notice of appeal shall state the basis for the appeal of the decision of the Affirmative Action Division Manager. The Appeal shall take place in accordance with Madison General Ordinance 33.54.

## 2.6 SBE Requirements After Award of the Contract

The successful bidder shall identify SBE subcontractors, suppliers and vendors on the subcontractor list in accordance with the specifications. The Contractor shall submit a detailed explanation of any variances between the listing of SBE subcontractors, vendors and/or suppliers on the subcontractor list and the Contractor's SBE Compliance Report for SBE participation.

No change in SBE subcontractors, vendors and/or suppliers from those SBEs indicated in the SBE Compliance Report will be allowed without prior approval from the Engineer and the Affirmative Action Division. The contractor shall submit in writing to the City of Madison Affirmative Action Division a request to change any SBE citing specific reasons which necessitate such a change. The Affirmative Action Division will use a general test of reasonableness in approving or rejecting the contractor's request for change. If the request is approved, the Contractor will make every effort to utilize another SBE if available.

The City will monitor the project to ensure that the actual percentage commitment to SBE firms is carried out.

## **2.7 SBE Definition and Eligibility Guidelines**

A Small Business Enterprise is a business concern awarded certification by the City of Madison. For the purposes of this program a Small Business Enterprise is defined as:

- A. An independent business operated under a single management. The business may not be a subsidiary of any other business and the stock or ownership may not be held by any individual or any business operating in the same or a similar field. In determining whether an entity qualifies as a SBE, the City shall consider all factors relevant to being an independent business including, but not limited to, the date the business was established, adequacy of its resources for the work in which it proposes to involve itself, the degree to which financial, equipment leasing and other relationships exist with other ineligible firms in the same or similar lines of work. SBE owner(s) shall enjoy the customary incidents of ownership and shall share in the risks and profits commensurate with their enjoyment interests, as demonstrated by an examination of the substance rather than form or arrangements that may be reflected in its ownership documents.
- B. A business that has averaged no more than \$4.0 million in annual gross receipts over the prior three year period and the principal owner(s) do not have a personal net worth in excess of \$1.32 million.

Firm and/or individuals that submit fraudulent documents/testimony may be barred from doing business with the City and/or forfeit existing contracts.

SBE certification is valid for one (1) year unless revoked.



## SECTION D: SPECIAL PROVISIONS

### SUMMIT MAINTENANCE FACILITY IMPROVEMENTS 2021 CONTRACT NO. 9055

It is the intent of these Special Provisions to set forth the final contractual intent as to the matter involved and shall prevail over the Standard Specifications and plans whenever in conflict therewith. In order that comparisons between the Special Provisions can be readily made, the numbering system for the Special Provisions is equivalent to that of the Specifications.

Whenever in these Specifications the term "Standard Specifications" appears, it shall be taken to refer to the City of Madison Standard Specifications for Public Works Construction and Supplements thereto.

#### **SECTION 102.11: BEST VALUE CONTRACTING**

This Contract shall be considered a Best Value Contract if the Contractor's bid is equal to or greater than \$65,000 for a single trade contract; or equal to or greater than \$318,000 for a multi-trade contract pursuant to MGO 33.07(7).

#### **SECTION 104: SCOPE OF WORK**

This project consists of resurfacing of the asphalt maintenance yard at Parks' Summit West Maintenance Facility. Work includes removing the existing curb and gutter, pulverizing the existing asphalt, installing new concrete curb and gutter, making grading improvements, and installing a new layer of asphalt pavement.

The Contractor shall view the site prior to bidding to become familiar with the existing conditions.

#### **SECTION 104.4: INCREASED OR DECREASED QUANTITIES**

It is agreed and understood that the quantities of any items of work shown on the plans or in the proposal are subject to increase or decrease during the progress of the work. The Engineer reserves the right to increase or decrease the quantities of any items of work, including increase or decrease of quantities by alteration of plans, as may be considered necessary or desirable during the progress of the work to satisfactorily complete the project. Such increases or decreases in quantities shall not be considered as a waiver of any conditions of the contract nor invalidate any of the provisions thereof. All terms of Section 104.5 Increase Items and Section 104.6 Decreased and Deleted Items of the Standard Specifications for Public Works Construction are applicable to this project.

All items shall be paid as plan quantity as listed in the proposal without measurement thereof. Unless there is a substantial change, no payment shall be given for changes in plan quantities listed in proposal. "Substantial" shall mean changes over 30% of the estimated plan quantity.

Items listed as "Undistributed" on the proposal page shall only be paid if determined necessary by the Engineer and shall be measured in the field by the Engineer.

#### **SECTION 105.1: AUTHORITY OF THE ENGINEER**

The Engineer shall resolve all questions which arise as to the quality and acceptability of materials furnished, work performed, manner of performance, rate of progress of the work, interpretation of the plans and Specifications, acceptable fulfillment of the contract, compensation, and disputes and mutual rights between Contractors under the Specifications. The Engineer shall determine the amount and quantity of work performed and materials furnished.

All decisions of the Engineer shall, when so requested, be rendered in writing. They shall be final and conclusive in all matters unless within ten (10) days after such decision the Contractor applies in writing to the Board of Public Works for a review of such decision.

Any change proposed by a Contractor in SBE subcontractors, vendors or suppliers from those SBEs indicated on the SBE Compliance Report must be approved by the Engineer and the City's Manager of the Affirmative Action Division (hereafter, AAD). When requested, such decision shall be rendered in writing. Such decisions shall be final and conclusive in all matters unless within ten (10) days after such decision the Contractor or the affected SBE applies in writing to the Board of Public Works for a review of such decision.

In the event the Engineer and the AAD disagree over the proper decision to be made regarding an SBE, the Mayor shall appoint a third person to resolve the disagreement, within 30 days of appointment. The decision thus rendered may be reviewed by the Board of Public Works upon request of the Contractor or the affected SBE as set forth in Sections 105.1 and 105.2 of the City's standard specifications.

**SECTION 105.9: SURVEYS, POINTS, AND INSTRUCTION**

The City of Madison shall be responsible for setting all lines and/or grades required to complete the work for Summit West Maintenance Facility Improvements 2021. Any questions regarding the layout and staking of this project should be directed to City of Madison Parks Surveyor Dan Rodman at (608) 658-3087.

**SECTION 105.12: COOPERATION BY CONTRACTOR**

Several utilities exist on site. The Contractor shall perform a One Call through Digger's Hotline at least three days prior to beginning construction. To ensure that Parks-owned utilities are also marked, include the PARK NAME AT THE BEGINNING OF THE MARKING instructions field on the ticket, and send a copy of the ticket to the City of Madison Parks Surveyor (Dan Rodman / [drodman@cityofmadison.com](mailto:drodman@cityofmadison.com) / tel (608)266-6674 / fax (608)267-1162).

The Contractor shall secure materials at the end of each work day to deter any potential vandalism and theft.

There exists a chain link fence around the site. The Contractor may remove the chain link fence if they choose, in order to install the curb and gutter. All sections of fence must be restored at the completion of the project. Removal and replacement of the chain link fence shall be done at the Contractor's discretion and shall not be paid by the City.

The site shall be secured at all times. The Contractor shall ensure that all construction fencing and barricades are erect and without gaps at the end of each work day. If existing chain link fence on site is removed by the Contractor, temporary construction fencing shall be erected in it's place while construction activities are under way. If temporary construction fence is needed it shall be installed at Contractor's expense.

A pre-construction meeting will be required prior to the start of construction.

Matting and seeding quantities are included for all areas disturbed during site access and construction activities. All areas disturbed shall be seeded and matted and Contractor is responsible for obtaining seed germination per Article 207 of the Standard Specifications, regardless of site conditions.

Seeding, matting, and erosion control quantities shall only be paid plan quantity without measurement thereof unless mutually agreed to by Contractor and project Engineer.

All work, materials, labor, tools, equipment, disposal, and incidentals required to complete the work to secure the site as described above shall be considered incidental to mobilization and no additional compensation shall be provided.

The Contractor warrants that its services are performed, within the limits prescribed by the City, with the usual thoroughness and competence of the consulting profession; in accordance with the standard for

professional services at the time those services are rendered. The Contractor shall be responsible for the accuracy of the work performed under this Agreement, and shall promptly make necessary revisions or corrections resulting from their negligent acts, errors or omissions without additional compensation. The Contractor shall be responsible for any damages incurred as a result of their errors, omissions, or negligent acts and for any losses or costs to repair or remedy construction.

All pavement surfaces shall maintain a minimum grade of 0.5% unless approved in writing by the Engineer. Final asphalt surface grades shall be within 0.5% of specified grades shown on the plans and it shall be the Contractor's responsibility to ensure final asphalt grades are accurate and within this margin of error.

Under no circumstances shall water pond on finished asphalt surfaces. If final asphalt grades are not within the acceptable margin of error, or are found to pond water, the Contractor shall remove and replace the asphalt at no additional cost to the City.

Parks shall remove all equipment and materials from the south maintenance yard prior to construction. The contractor shall have access to the entire lot during construction dates. The contractor shall maintain pedestrian access to all building for Parks staff at all times. If vehicle access is needed to the site by Parks staff the contractor shall receive 48 hours' notice and shall provide requested temporary access at a mutually agreed upon time.

**SECTION 107.7: MAINTENANCE OF TRAFFIC**

The Contractor may stage equipment within the disturbance limits shown on the plans.

Contractor may post temporary "no parking" signs on the east side of the 1900 block of Freeport Road to stage equipment. The Contractor shall contact John Villareal with the City of Madison Parking Utility (608-267-8756) at least 7 working days prior to needing the signs. Contractor shall post signs in accordance with the City of Madison Police Department Guidelines for temporary no parking restrictions for construction or special events. Signs must be posted and verified by City Parking Enforcement at least 48 hours in advance of towing. The guidelines can be found at the link listed below. This shall be considered incidental to the mobilization lump sum bid item.

[www.cityofmadison.com/business/pw/documents/guidelines\\_temporarynoparkingrestrictions.pdf](http://www.cityofmadison.com/business/pw/documents/guidelines_temporarynoparkingrestrictions.pdf)

All signing and barricading shall conform to Part VI of the Federal Highways Administrations "Manual on Uniform Traffic Control Devices" (MUTCD), the State of Wisconsin Standard Facilities Development Manual (including Chapter 16 – Standard Detail Drawings) and the City of Madison Standards for sidewalk and bikeway closures.

The Contractor shall be responsible for installing and maintaining traffic control in accordance with the approved Traffic Control Plan and as directed by the City Traffic Engineer. The traffic control plan may need to be altered as conditions change in the field or as unexpected conditions occur. This may include relocating existing traffic control or providing additional traffic control. The Contractor shall install and maintain any necessary modifications or additions to the traffic control, as directed by the City Traffic Engineer, at no cost to the City.

**SECTION 108.2: PERMITS**

The following permits have been applied for by the City of Madison for the site:

1. City of Madison Erosion Control Permit

**SECTION 109.2: PROSECUTION OF THE WORK**

The Contractor shall begin work on this project on **September 22, 2021**, or as soon as the contract has been fully executed.

The date of completion shall be **December 1st, 2021**. All asphalt paving shall be in accordance with Section 402.2 of the City of Madison Standard Specifications.

Work cannot start on this contract until after the "Start to Work" letter has been received. Construction work must begin within seven (7) calendar days after the date appearing on the mailed notice to do so that was sent to the Contractor. Construction work shall be carried at a rate so as to secure full completion within the contract times outlined in Section 109.7, the rate of progress and the time of completion being essential conditions of this Agreement. Definite notice of intention to start work shall be given to the Engineer at least seventy-two (72) hours in advance of beginning work.

The fixed, agreed upon, liquidated damages for failure to complete all work within the contract, unless otherwise specified in this section, shall be calculated in accordance with Article 109 of the Standard Specifications. The Contractor shall limit workdays from 7:00 am to 7:00 pm, Monday - Friday, unless approved by the Engineer in writing.

### **BID ITEM 10911 - MOBILIZATION**

#### **DESCRIPTION**

Work under this item shall include all costs associated with mobilization of the Contractor the site location. Parking of equipment, storage of materials, and staging shall only be allowed within the disturbance limits shown on plans and as outlined under Section 107.7. The Contractor may only enter the construction site through the construction entrance as shown on the plans. The Contractor may not drive or store equipment on any portion of the property outside the disturbance limits unless indicated otherwise on plans or directed in the field.

### **BID ITEM 20101 – EXCAVATION CUT**

#### **DESCRIPTION**

Excavation Cut shall consist of the loosening, loading, hauling and disposal of all materials. Excavation cut shall be in accordance with Article 201 of the Standard Specifications.

Excavation cut quantities include the following items:

- Removal of existing topsoil and excavation to subgrade as shown on the plans
- Removal of existing block style curb and material necessary to install new curb and gutter
- Subgrade material to be removed in order to achieve final grades

All other removal and excavation items shall be paid under the appropriate bid item. No shrinkage factor has been applied to fill quantities to estimate net volume. The Contractor is responsible to review earthwork calculations. Three-dimensional AutoCAD (.dwg) files containing the digital terrain models used for the earthwork calculations are available upon request.

The difference in Three-dimensional AutoCAD (.dwg) files surface models is approximately 74 cubic yards.

Adjustments were made for topsoil assuming excavation of six (6) inches of existing topsoil, placement of six (6) inches of proposed topsoil.

Excess excavated material deemed unusable shall be disposed of off-site at a suitable location determined by the Contractor at no additional cost to the City of Madison.

Suitable materials (to be determined by the Engineer) may be reused as fill within the project limits. Placement of these fill materials shall be considered incidental to this bid item and shall not be compensated separately. All double handling and subsoil placement is included in this bid item.

Any additional undercut required due to field conditions shall be paid for under BID ITEM 40321 – UNDERCUT (UNDISTRIBUTED.)

Test rolling for undercut determination is required at all sites and is incidental to this bid item. Test rolling shall be done with a fully loaded tri axle dump truck. Contractor shall notify Engineer at least 24 hours prior to test rolling. There shall be no rain allowed on site between test rolling and paving.

Contractor to note all excavated areas shall be filled at the end of each work day. No excavated areas shall be "open" during non-work hours.

The Contractor shall be allowed to reuse gravel, and pulverize existing gravel to be used onsite. However, the Contractor shall note that in some areas the proposed grade shall be lower than the existing grade, and any reused material will have to be temporarily stored while subgrade is prepared. An approximation of this area is shown on the plans. No additional compensation shall be paid for double handling of materials.

The contractor shall maintain a minimum depth of pulverized material and base course of 8 inches. In these areas it may be necessary to remove all pulverized material and base course, regrade the subgrade, and place pulverized material to meet new grades. Removal of required sub base material has been included in the Excavation Cut quantities and shall be paid under this item. All regrading of the sub base including removal and handling of materials shall be included in this item.

It is anticipated that extra material shall be generated from the pulverizing and shaping of the lot. The Contractor shall remove and dispose of any excess material at a site determined by the Contractor at no additional cost to the City.

#### **BID ITEM 20217 – CLEAR STONE**

##### **DESCRIPTION**

The quantity of clear stone included in this contract is sufficient to construct a construction entrance and stone berms as shown on plans. If the Contractor chooses to use additional clear stone it shall be at no additional cost to the City.

##### **METHOD OF MEASUREMENT**

Clear Stone shall be measured by the ton as listed in the proposal page without measurement thereof.

##### **BASIS OF PAYMENT**

Clear Stone shall be measured as described above and shall be paid for at the contract unit price which shall be full compensation for all work, materials, labor, tools, equipment, disposal, and incidentals required to complete the work as set forth in the description.

#### **BID ITEM 20221 - TOPSOIL**

##### **DESCRIPTION**

This item shall include all necessary work, labor and incidentals required to distribute, dispose and/or place topsoil to meet proposed grades. Topsoil shall comply with Article 202 of the Standard Specifications.

Stripped topsoil can be stockpiled on site within the fence boundary.

The topsoil quantities for this contract have been computed by AutoCAD Civil 3D surface data volume computations and the assumptions listed above. Adjustments were made for topsoil assuming

excavation of six (6) inches of existing topsoil. Any additional topsoil material required beyond quantities available through stripped topsoil are incidental to this bid item.

Excess topsoil shall be disposed offsite at a location to be determined and provided by the City at no extra cost to the City. Double handling, stockpiling and placing topsoil is included in this bid item.

**Contractor to note - the Engineer is to be called to inspect and approve the finish grade prior to seeding and mulching. Contractor shall provide a minimum 24 hours notice to Engineer when inspection is requested.**

#### **METHOD OF MEASUREMENT**

Topsoil shall be measured as each SY placed in the field as listed in the proposal page without measurement thereof.

#### **BASIS OF PAYMENT**

Topsoil shall be measured as described above and shall be paid for at the contract unit price which shall be full compensation for all work, materials, labor, tools, equipment, disposal, and incidentals required to complete the work as set forth in the description.

#### **BID ITEM 21011 – CONSTRUCTION ENTRANCE**

##### **DESCRIPTION**

Work under this item shall include the placement of a stone pad and paid as a construction entrance at the location shown in the plans and in accord with the City of Madison Standard Specifications and with the approval of the Engineer.

Construction entrance shall be constructed at the size and location as approved by the Engineer. The Contractor shall place stone, ramping, and/or plating to avoid damage to concrete or asphalt. If any concrete or asphalt is damaged during construction the Contractor shall remove and replace damaged sections at no additional cost to the City. The Engineer shall determine any damaged sections to be replaced.

##### **METHOD OF MEASUREMENT**

Construction Entrance shall be measured as each pad placed in the field as listed in the proposal page without measurement thereof.

##### **BASIS OF PAYMENT**

Construction Entrance shall be measured as described above and shall be paid for at the contract unit price which shall be full compensation for all work, materials, labor, tools, equipment, disposal, and incidentals required to complete the work as set forth in the description.

#### **BID ITEM 40321 – UNDERCUT (UNDISTRIBUTED)**

##### **DESCRIPTION**

This bid item has been included in the event that undercut is necessary for construction of the asphalt. This item may be eliminated if undercut is not required. Contractor shall determine need and quantity for undercut and notify the Engineer of intent to undercut any areas prior to beginning undercut excavation.

**METHOD OF MEASUREMENT**

Undercut (undistributed) shall be measured per CY in the field as listed in the proposal page without measurement thereof.

**BASIS OF PAYMENT**

Undercut (undistributed) shall be measured as described above and shall be paid for at the contract unit price which shall be full compensation for all work, materials, labor, tools, equipment, disposal, and incidentals required to complete the work as set forth in the description.

**BID ITEM 90000 – REMOVE BOLLARD**

**DESCRIPTION**

Work under this item shall include all work, materials, labor and incidentals necessary for the Contractor to remove an existing bollard located outside the garage doors on site. It is anticipated that each bollard contains a concrete footing and the entire bollard, including footing, shall be removed. All materials shall be disposed of by the Contractor.

**METHOD OF MEASUREMENT**

Remove Bollard shall be measured as each unit removed in the field as listed in the proposal page without measurement thereof.

**BASIS OF PAYMENT**

Remove Bollard shall be measured as described above and shall be paid for at the contract unit price which shall be full compensation for all work, materials, labor, tools, equipment, disposal, and incidentals required to complete the work as set forth in the description.

**BID ITEM 90001 –BOLLARD**

**DESCRIPTION**

Work under this item shall include all work, materials, labor and incidentals necessary for the Contractor to provide and install a bollard as shown on the plans and on page AS-2 of these Special Provisions.

**METHOD OF MEASUREMENT**

Bollard shall be measured as each unit installed in the field as listed in the proposal page without measurement thereof.

**BASIS OF PAYMENT**

Bollard shall be measured as described above and shall be paid for at the contract unit price which shall be full compensation for all work, materials, labor, tools, equipment, disposal, and incidentals required to complete the work as set forth in the description.

**BID ITEM 90002 – BIKE RACK**

**DESCRIPTION**

Work under this item shall include all work, materials, labor and incidentals necessary for the Contractor to provide and install a bike rack as shown on the plans. Bike rack shall be Saris model 2450 or approved equivalent. Color shall be approved by Engineer prior to installation. Racks shall be installed per manufacturer's recommendations using stainless steel hardware. Racks shall be centered in the

concrete sidewalk installation pad and placed 4 feet on center. Concrete pad shall be paid separately under Bid Item 30301 5 Inch Concrete Sidewalk.

**METHOD OF MEASUREMENT**

Bike Rack shall be measured as each rack installed in the field as listed in the proposal page without measurement thereof.

**BASIS OF PAYMENT**

Bike Rack shall be measured as described above and shall be paid for at the contract unit price which shall be full compensation for all work, materials, labor, tools, equipment, disposal, and incidentals required to complete the work as set forth in the description.

**BID ITEM 90003 –STOP SIGN**

**DESCRIPTION**

Work under this item shall include all necessary work, labor and incidentals required to install new signs in accordance with the Wisconsin Manual on Uniform Traffic Control Devices and Wisconsin Department of Transportation Signing Guidelines Manual. Stop sign shall be installed at a height of 7'. Sign type and location are shown on page 1.3 of the plans.

Signs shall comply with S.D.D. 6.43 and include concrete base per S.D.D. 6.42.

**METHOD OF MEASUREMENT**

Traffic and Parking Lot Signs shall be measured per each individual sign.

**BASIS OF PAYMENT**

Traffic and Parking Lot Signs shall be measured as described above and shall be paid for at the contract unit price which shall be full compensation for all work, materials, labor, tools, equipment, disposal, and incidentals required to complete the work as set forth in the description





# Madison Parks Division

210 Martin Luther King, Jr. Blvd., Room 104  
PO Box 2987  
Madison, WI 53701-2987  
608-266-4711 • cityofmadison.com/parks

*play*  
**MADISON  
PARKS**

August 2, 2021

## NOTICE OF ADDENDUM ADDENDUM NO. 1

CONTRACT NO. 9055

Revise and amend the contract document(s) for the above project as stated in this addendum, otherwise, the original document shall remain in effect.

Revise Plans:

- Attach Sheet AS-2 to Special Provisions

Revise Special Provisions as follows:

Under **BID ITEM 90002 – BIKE RACK**

Revise the following:

### DESCRIPTION

Work under this item shall include all work, materials, labor and incidentals necessary for the Contractor to provide and install a bike rack as shown on the plans. Bike rack shall be Saris "Bike Dock" or approved equivalent. Color shall be approved by Engineer prior to installation. Racks shall be installed per manufacturer's recommendations using stainless steel hardware. Racks shall be centered in the concrete sidewalk installation pad and placed 4 feet on center. Concrete pad shall be paid separately under Bid Item 30301 5 Inch Concrete Sidewalk.

Please acknowledge this addendum on page E1 of the contract documents and/or in Section E: Bidder's Acknowledgement on Bid Express.

Electronic version of these documents can be found on the Bid Express web site at:

<http://www.bidexpress.com>

If you are unable to download plan revisions associated with the addendum, please contact the Engineering office at 608-266-4751 receive the material by another route.

  
Eric Knepp, Parks Superintendent

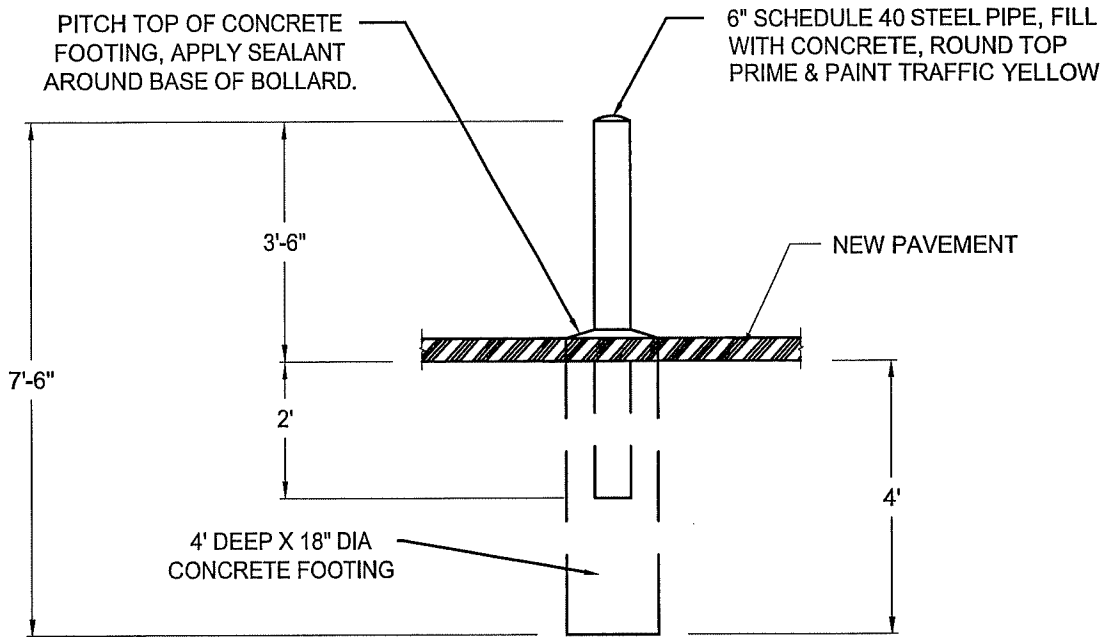

**1**  
**AS-2**
**SAFETY BOLLARD**  
**DETAIL**      NOT TO SCALE

**AS-2**

8/23/2019

SECTION E: BIDDERS ACKNOWLEDGEMENT

SUMMIT MAINTENANCE FACILITY IMPROVEMENTS 2021  
CONTRACT NO. 9055

Bidder must state a Unit Price and Total Bid for each item. The Total Bid for each item must be the product of quantity, by Unit Price. The Grand Total must be the sum of the Total Bids for the various items. In case of multiplication errors or addition errors, the Grand Total with corrected multiplication and/or addition shall determine the Grand Total bid for each contract. The Unit Price and Total Bid must be entered numerically in the spaces provided. All words and numbers shall be written in ink.

1. The undersigned having familiarized himself/herself with the Contract documents, including Advertisement for Bids, Instructions to Bidders, Form of Proposal, City of Madison Standard Specifications for Public Works Construction - 2021 Edition thereto, Form of Agreement, Form of Bond, and Addenda issued and attached to the plans and specifications on file in the office of the City Engineer, hereby proposes to provide and furnish all the labor, materials, tools, and expendable equipment necessary to perform and complete in a workmanlike manner the specified construction on this project for the City of Madison; all in accordance with the plans and specifications as prepared by the City Engineer, including Addenda Nos. 1 through 1 to the Contract, at the prices for said work as contained in this proposal. (Electronic bids submittals shall acknowledge addendum under Section E and shall not acknowledge here)
2. If awarded the Contract, we will initiate action within seven (7) days after notification or in accordance with the date specified in the contract to begin work and will proceed with diligence to bring the project to full completion within the number of work days allowed in the Contract or by the calendar date stated in the Contract.
3. The undersigned Bidder or Contractor certifies that he/she is not a party to any contract, combination in form of trust or otherwise, or conspiracy in restraint of trade or commerce or any other violation of the anti-trust laws of the State of Wisconsin or of the United States, with respect to this bid or contract or otherwise.
4. I hereby certify that I have met the Bid Bond Requirements as specified in Section 102.5. (IF BID BOND IS USED, IT SHALL BE SUBMITTED ON THE FORMS PROVIDED BY THE CITY. FAILURE TO DO SO MAY RESULT IN REJECTION OF THE BID).
5. I hereby certify that all statements herein are made on behalf of Speedway Sand & Gravel Inc. (name of corporation, partnership, or person submitting bid) a corporation organized and existing under the laws of the State of Wisconsin a partnership consisting of \_\_\_\_\_; an individual trading as \_\_\_\_\_; of the City of \_\_\_\_\_ State of \_\_\_\_\_; that I have examined and carefully prepared this Proposal, from the plans and specifications and have checked the same in detail before submitting this Proposal; that I have fully authority to make such statements and submit this Proposal in (its, their) behalf, and that the said statements are true and correct.

*Janice Ryan*  
 SIGNATURE  
 Corporate Secretary  
 TITLE, IF ANY

Sworn and subscribed to before me this  
15th day of August, 2021.

*Katie Lightie*  
 (Notary Public or other officer authorized to administer oaths)  
 My Commission Expires 01-01-23

Bidders shall not add any conditions or qualifying statements to this Proposal.

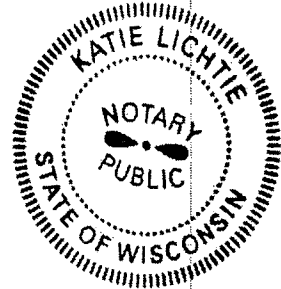



Contract 9055 – Speedway Sand & Gravel, Inc.

Section F: Best Value Contracting (BVC)

This section is a required document for the bid to be considered complete. There are two methods for completing the Best Value Contracting (BVC) form. Method one: The form can be filled out online and submitted to this site to be included with your electronic bid. Method two: The form can be downloaded from the site and submitted by hand to the City of Madison.

Method of Submittal for BVC (click in box below to choose) \*

I will submit Bid Express fillable online form (BVC).

Best Value Contracting

1. The Contractor shall indicate the non-apprenticeable trades used on this contract.

2. Madison General Ordinance (M.G.O.), 33.07(7), does provide for some exemptions from the active apprentice requirement. Apprenticeable trades are those trades considered apprenticeable by the State of Wisconsin. Please check applicable box if you are seeking an exemption.

- Contractor has a total skilled workforce of four or less individuals in all apprenticeable trades combined.
- No available trade training program; The Contractor has been rejected by the only available trade training program, or there is no trade training program within 90 miles.
- Contractor is not using an apprentice due to having a journey worker on layoff status, provided the journey worker was employed by the contractor in the past six months.
- First time contractor on City of Madison Public Works contract requests a onetime exemption but intends to comply on all future contracts and is taking steps typical of a "good faith" effort.
- Contractor has been in business less than one year.
- Contractor doesn't have enough journeyman trade workers to qualify for a trade training program in that respective trade.
- An exemption is granted in accordance with a time period of a "Documented Depression" as defined by the State of Wisconsin.

3. The Contractor shall indicate on the following section which apprenticeable trades are to be used on this contract. Compliance with active apprenticeship, to the extent required by M.G.O. 33.07(7), shall be satisfied by documentation from an applicable trade training body; an apprenticeship contract with the Wisconsin Department of Workforce Development or a similar agency in another state; or the U.S Department of Labor. This documentation is required prior to the Contractor beginning work on the project site.

The Contractor has reviewed the list and shall not use any apprenticeable trades on this project.

LIST APPRENTICABLE TRADES (check all that apply to your work to be performed on this contract)

- BRICKLAYER
- CARPENTER
- CEMENT MASON / CONCRETE FINISHER
- CEMENT MASON (HEAVY HIGHWAY)
- CONSTRUCTION CRAFT LABORER
- DATA COMMUNICATION INSTALLER
- ELECTRICIAN
- ENVIRONMENTAL SYSTEMS TECHNICIAN / HVAC SERVICE TECH/HVAC INSTALL / SERVICE
- GLAZIER
- HEAVY EQUIPMENT OPERATOR / OPERATING ENGINEER
- INSULATION WORKER (HEAT and FROST)
- IRON WORKER
- IRON WORKER (ASSEMBLER, METAL BLDGS)
- PAINTER and DECORATOR
- PLASTERER
- PLUMBER
- RESIDENTIAL ELECTRICIAN
- ROOFER and WATER PROOFER
- SHEET METAL WORKER
- SPRINKLER FITTER
- STEAMFITTER
- STEAMFITTER (REFRIGERATION)
- STEAMFITTER (SERVICE)
- TAPER and FINISHER
- TELECOMMUNICATIONS (VOICE, DATA and VIDEO) INSTALLER-TECHNICIAN
- TILE SETTER

**SUMMIT MAINTENANCE FACILITY IMPROVEMENTS 2021  
CONTRACT NO. 9055**

**Small Business Enterprise Compliance Report**

This information may be submitted electronically through  
Bid Express or submitted with bid in sealed envelope.

**Cover Sheet**

Prime Bidder Information

Company: Speedway Sand & Gravel Inc.  
Address: 8500 Greenway Blvd Suite 202, Middleton, WI 53562  
Telephone Number: 608-836-1071 Fax Number: 608-836-7485  
Contact Person/Title: Janice Ryan, Corp Secretary

Prime Bidder Certification

I, Janice Ryan, Corporate Secretary of  
Name Title  
Speedway Sand & Gravel Inc. certify that the information  
Company

contained in this SBE Compliance Report is true and correct to the best of my knowledge and belief.

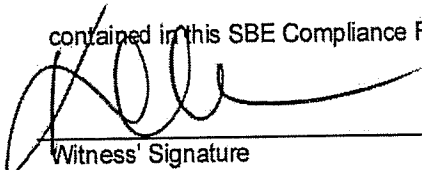
  
\_\_\_\_\_  
Witness' Signature

  
\_\_\_\_\_  
Bidder's Signature

August 5, 2021  
\_\_\_\_\_  
Date





**SUMMIT MAINTENANCE FACILITY IMPROVEMENTS 2021**

CONTRACT NO. 9055  
DATE: 8/5/2021

**Speedway Sand & Gravel,  
Inc.**

Item	Quantity	Price	Extension
<b>Section B: Proposal Page</b>			
10911.0 - MOBILIZATION - LS	1.00	\$15,387.00	\$15,387.00
20101.0 - EXCAVATION CUT - CY	173.00	\$48.90	\$8,459.70
20140.0 - GEOTEXTILE FABRIC TYPE SAS NON WOVEN (UNDISTRIBUTED) - SY	175.00	\$4.00	\$700.00
20217.0 - CLEAR STONE - TON	42.00	\$21.00	\$882.00
20219.0 - BREAKER RUN (UNDISTRIBUTED) - TON	116.00	\$9.60	\$1,113.60
20221.0 - TOPSOIL - SY	293.00	\$9.65	\$2,827.45
20303.0 - SAWCUT ASPHALT PAVEMENT - LF	16.00	\$10.00	\$160.00
20701.0 - TERRACE SEEDING - SY	293.00	\$2.80	\$820.40
21011.0 - CONSTRUCTION ENTRANCE - EA	1.00	\$765.00	\$765.00
21013.0 - STREET SWEEPING - LS	1.00	\$475.00	\$475.00
21017.0 - SILT SOCK (8 INCH) - COMPLETE - LF	188.00	\$8.00	\$1,504.00
21049.0 - INLET PROTECTION, RIGID FRAME - PROVIDE AND INSTALL - EA	1.00	\$325.00	\$325.00
21050.0 - INLET PROTECTION, RIGID FRAME - MAINTAIN - EA	1.00	\$200.00	\$200.00
21051.0 - INLET PROTECTION, RIGID FRAME - REMOVE - EA	1.00	\$100.00	\$100.00
21061.0 - EROSION MATTING, CLASS I URBAN TYPE A - SY	293.00	\$3.50	\$1,025.50
30201.0 - TYPE "A" CONCRETE CURB & GUTTER - L.F.	388.00	\$29.60	\$11,484.80
30301.0 - 5 INCH CONCRETE SIDEWALK - S.F.	72.00	\$6.80	\$489.60
30302.0 - 7 INCH CONCRETE SIDEWALK & DRIVE - S.F.	671.00	\$7.50	\$5,032.50
40102.0 - CRUSHED AGGREGATE BASE COURSE, GRADATION NO. 2 OR NO. 3 - TON	185.00	\$10.00	\$1,850.00
40202.0 - HMA PAVEMENT 4 LT 58-28 S - TON	361.00	\$84.90	\$30,648.90
40218.0 - TACK COAT - GAL	177.00	\$3.00	\$531.00
40301.0 - FULL WIDTH GRINDING - SY	89.00	\$40.00	\$3,560.00
40311.0 - PULVERIZE AND SHAPE - SY	1750.00	\$1.25	\$2,187.50
40321.0 - UNDERCUT (UNDISTRIBUTED) - CY	58.00	\$48.50	\$2,813.00
50225.0 - UTILITY TRENCH PATCH TYPE III - TF	10.00	\$60.00	\$600.00
50401.0 - 12 INCH TYPE I RCP STORM SEWER PIPE - LF	42.00	\$125.01	\$5,250.42
50211.0 - SELECT BACKFILL FOR STORM SEWER - TF	42.00	\$0.01	\$0.42
50741.0 - TYPE "H" INLET - EA	1.00	\$4,070.00	\$4,070.00
50792.0 - STORM SEWER TAP - EA	1.00	\$3,000.00	\$3,000.00
90000.0 - REMOVE BOLLARD - EA	4.00	\$275.00	\$1,100.00
90001.0 - BOLLARD - EA	4.00	\$560.00	\$2,240.00
90002.0 - BIKE RACK - EA	3.00	\$500.00	\$1,500.00
90003.0 - STOP SIGN - EACH	1.00	\$432.10	\$432.10
33 Items	Totals		\$111,534.89





Department of Public Works  
**Engineering Division**  
 Robert F. Phillips, P.E., City Engineer  
 City-County Building, Room 115  
 210 Martin Luther King, Jr. Boulevard  
 Madison, Wisconsin 53703  
 Phone: (608) 266-4751  
 Fax: (608) 264-9275  
[engineering@cityofmadison.com](mailto:engineering@cityofmadison.com)  
[www.cityofmadison.com/engineering](http://www.cityofmadison.com/engineering)

**Deputy City Engineer**  
 Gregory T. Fries, P.E.

**Deputy Division Manager**  
 Kathleen M. Cryan

**Principal Engineer 2**  
 Christopher J. Petykowski, P.E.  
 John S. Fahrney, P.E.

**Principal Engineer 1**  
 Christina M. Bachmann, P.E.  
 Mark D. Moder, P.E.  
 Janet Schmidt, P.E.  
 James M. Wolfe, P.E.

**Facilities & Sustainability**  
 Bryan Cooper, Principal Architect

**Mapping Section Manager**  
 Eric T. Pederson, P.S.

**Financial Manager**  
 Steven B. Danner-Rivers

**BIENNIAL BID BOND**

Speedway Sand & Gravel, Inc.

(a corporation of the State of Wisconsin)  
 (individual), (partnership), (hereinafter referred to as the "Principal") and  
 Fidelity and Deposit Company of Maryland

a corporation of the State of Maryland (hereinafter referred to as the "Surety") and licensed to do business in the State of Wisconsin, are held and firmly bound unto the City of Madison, Wisconsin (hereinafter referred to as the "City"), in the sum equal to the individual proposal guaranty amounts of the total bid or bids of the Principal herein accepted by the City, for the payment of which the Principal and the Surety hereby jointly and severally bind ourselves, our heirs, executors, administrators, successors and assigns.

The condition of this obligation is that the Principal has submitted to the City certain bids for projects from the time period of February 1, 2020 through January 31, 2022.

If the Principal is awarded the contract(s) by the City and, within the time and manner required by law after the prescribed forms are presented for its signature, the Principal enters into (a) written contract(s) in accordance with the bid(s), and files with the City its bond(s) guaranteeing faithful performance and payment for all labor and materials, as required by law, or if the City rejects all bids for the work described, then this obligation shall be null and void; otherwise, it shall remain in full force and effect.

In the event the Principal shall fail to execute and deliver the contract(s) or the performance and payment bond(s), all within the time specified or any extension thereof, the Principal and Surety agree jointly and severally to pay to the City within ten (10) calendar days of written demand a total equal to the sum of the individual proposal guaranty amounts of the total bid(s) as liquidated damages.

The Surety, for value received, hereby agrees that the obligations of it and its bond shall be in no way impaired or affected by any extension of time within which the City may accept a bid, and the Surety does hereby waive notice of any such extension.

This bond may be terminated by the Surety upon giving thirty (30) days written notice to the City of its intent to terminate this bond and to be released and discharged therefrom, but such termination shall not operate to relieve or discharge the Surety from any liability already accrued or which shall accrue before the expiration of such thirty (30) day period.

IN WITNESS WHEREOF, the Principal and the Surety have hereunto set their hands and seals, and such of them as are corporations have caused their corporate seals to be hereto affixed and these presents to be signed by their proper officers, on the day and year set forth below.

**PRINCIPAL**

Speedway Sand & Gravel, Inc.  
COMPANY NAME AFFIX SEAL

November 11, 2019  
DATE

By: *Amie Ryan*  
SIGNATURE AND TITLE Corp Sec.

**SURETY**

Fidelity and Deposit Company of Maryland  
COMPANY NAME AFFIX SEAL

November 11, 2019  
DATE

By: *Nicole Stillings*  
SIGNATURE AND TITLE  
Nicole Stillings, Attorney-in-Fact

This certifies that I have been duly licensed as an agent for the Surety in Wisconsin under National Provider No. 6966174 for the year 2020 and appointed as attorney in fact with authority to execute this bid bond, which power of attorney has not been revoked.

November 11, 2019  
DATE

*Nicole Stillings*  
AGENT SIGNATURE

1600 Aspen Commons, Suite 990  
ADDRESS

Middleton, WI 53562  
CITY, STATE AND ZIP CODE

608-242-2551  
TELEPHONE NUMBER

Note to Surety and Principal: Any bid submitted which this bond guarantees may be rejected if the Power of Attorney form showing that the Agent of Surety is currently authorized to execute bonds on behalf of Surety is not attached to this bond.

**ZURICH AMERICAN INSURANCE COMPANY  
COLONIAL AMERICAN CASUALTY AND SURETY COMPANY  
FIDELITY AND DEPOSIT COMPANY OF MARYLAND  
POWER OF ATTORNEY**

KNOW ALL MEN BY THESE PRESENTS: That the ZURICH AMERICAN INSURANCE COMPANY, a corporation of the State of New York, the COLONIAL AMERICAN CASUALTY AND SURETY COMPANY, a corporation of the State of Illinois, and the FIDELITY AND DEPOSIT COMPANY OF MARYLAND a corporation of the State of Illinois (herein collectively called the "Companies"), by Robert D. Murray, Vice President, in pursuance of authority granted by Article V, Section 8, of the By-Laws of said Companies, which are set forth on the reverse side hereof and are hereby certified to be in full force and effect on the date hereof, do hereby nominate, constitute, and appoint Melinda C. BLODGETT, Colby D. WHITE, Jerome T. OUIMET, Nicole STILLINGS, John E. TAUER, Joshua R. LOFTIS, Kurt C. LUNDBLAD, Ted JORGENSEN, R. C. BOWMAN, and Brian J. OESTREICH, all of Minneapolis, Minnesota, EACH, its true and lawful agent and Attorney-in-Fact, to make, execute, seal and deliver, for, and on its behalf as surety, and as its act and deed: any and all bonds and undertakings, and the execution of such bonds or undertakings in pursuance of these presents, shall be as binding upon said Companies, as fully and amply, to all intents and purposes, as if they had been duly executed and acknowledged by the regularly elected officers of the ZURICH AMERICAN INSURANCE COMPANY at its office in New York, New York., the regularly elected officers of the COLONIAL AMERICAN CASUALTY AND SURETY COMPANY at its office in Owings Mills, Maryland., and the regularly elected officers of the FIDELITY AND DEPOSIT COMPANY OF MARYLAND at its office in Owings Mills, Maryland., in their own proper persons.

The said Vice President does hereby certify that the extract set forth on the reverse side hereof is a true copy of Article V, Section 8, of the By-Laws of said Companies, and is now in force.

IN WITNESS WHEREOF, the said Vice-President has hereunto subscribed his/her names and affixed the Corporate Seals of the said ZURICH AMERICAN INSURANCE COMPANY, COLONIAL AMERICAN CASUALTY AND SURETY COMPANY, and FIDELITY AND DEPOSIT COMPANY OF MARYLAND, this 26th day of June, A.D. 2019.



**ATTEST:**  
ZURICH AMERICAN INSURANCE COMPANY  
COLONIAL AMERICAN CASUALTY AND SURETY COMPANY  
FIDELITY AND DEPOSIT COMPANY OF MARYLAND

By: Robert D. Murray  
Vice President

By: Dawn E. Brown  
Secretary

State of Maryland  
County of Baltimore

On this 26th day of June, A.D. 2019, before the subscriber, a Notary Public of the State of Maryland, duly commissioned and qualified, Robert D. Murray, Vice President and Dawn E. Brown, Secretary of the Companies, to me personally known to be the individuals and officers described in and who executed the preceding instrument, and acknowledged the execution of same, and being by me duly sworn, deposeth and saith, that he/she is the said officer of the Company aforesaid, and that the seals affixed to the preceding instrument are the Corporate Seals of said Companies, and that the said Corporate Seals and the signature as such officer were duly affixed and subscribed to the said instrument by the authority and direction of the said Corporations.

IN TESTIMONY WHEREOF, I have hereunto set my hand and affixed my Official Seal the day and year first above written.



Constance A. Dunn, Notary Public  
My Commission Expires: July 9, 2023

**EXTRACT FROM BY-LAWS OF THE COMPANIES**

"Article V, Section 8, Attorneys-in-Fact. The Chief Executive Officer, the President, or any Executive Vice President or Vice President may, by written instrument under the attested corporate seal, appoint attorneys-in-fact with authority to execute bonds, policies, recognizances, stipulations, undertakings, or other like instruments on behalf of the Company, and may authorize any officer or any such attorney-in-fact to affix the corporate seal thereto; and may with or without cause modify or revoke any such appointment or authority at any time."

**CERTIFICATE**

I, the undersigned, Secretary of the ZURICH AMERICAN INSURANCE COMPANY, the COLONIAL AMERICAN CASUALTY AND SURETY COMPANY, and the FIDELITY AND DEPOSIT COMPANY OF MARYLAND, do hereby certify that the foregoing Power of Attorney is still in full force and effect on the date of this certificate; and I do further certify that Article V, Section 8, of the By-Laws of the Companies is still in force.

This Power of Attorney and Certificate may be signed by facsimile under and by authority of the following resolution of the Board of Directors of the ZURICH AMERICAN INSURANCE COMPANY at a meeting duly called and held on the 15th day of December 1998.

RESOLVED: "That the signature of the President or a Vice President and the attesting signature of a Secretary or an Assistant Secretary and the Seal of the Company may be affixed by facsimile on any Power of Attorney...Any such Power or any certificate thereof bearing such facsimile signature and seal shall be valid and binding on the Company."

This Power of Attorney and Certificate may be signed by facsimile under and by authority of the following resolution of the Board of Directors of the COLONIAL AMERICAN CASUALTY AND SURETY COMPANY at a meeting duly called and held on the 5th day of May, 1994, and the following resolution of the Board of Directors of the FIDELITY AND DEPOSIT COMPANY OF MARYLAND at a meeting duly called and held on the 10th day of May, 1990.

RESOLVED: "That the facsimile or mechanically reproduced seal of the company and facsimile or mechanically reproduced signature of any Vice-President, Secretary, or Assistant Secretary of the Company, whether made heretofore or hereafter, wherever appearing upon a certified copy of any power of attorney issued by the Company, shall be valid and binding upon the Company with the same force and effect as though manually affixed.

IN TESTIMONY WHEREOF, I have hereunto subscribed my name and affixed the corporate seals of the said Companies, this 11th day of November, 2019.



*Brian M. Hodges*

By: Brian M. Hodges  
Vice President

**TO REPORT A CLAIM WITH REGARD TO A SURETY BOND, PLEASE SUBMIT A COMPLETE DESCRIPTION OF THE CLAIM INCLUDING THE PRINCIPAL ON THE BOND, THE BOND NUMBER, AND YOUR CONTACT INFORMATION TO:**

Zurich Surety Claims  
1299 Zurich Way  
Schaumburg, IL 60196-1056  
[www.reportsfclaims@zurichna.com](mailto:www.reportsfclaims@zurichna.com)  
800-626-4577

## **CERTIFICATE OF BIENNIAL BID BOND**

TIME PERIOD- VALID (FROM/TO) February 1, 2020 - January 31, 2022
NAME OF SURETY Fidelity and Deposit Company of Maryland
NAME OF CONTRACTOR Speedway Sand & Gravel, Inc.
CERTIFICATE HOLDER City of Madison, Wisconsin

This is to certify that a biennial bid bond issued by the above-named Surety is currently on file with the City of Madison.

This certificate is issued as a matter of information and conveys no rights upon the certificate holder and does not amend, extend or alter the coverage of the biennial bid bond.

Cancellation: Should the above policy be cancelled before the expiration date, the issuing Surety will give thirty (30) days written notice to the certificate holder indicated above.

  
\_\_\_\_\_  
SIGNATURE OF AUTHORIZED CONTRACTOR REPRESENTATIVE

12-10-19  
\_\_\_\_\_  
DATE

## SECTION H: AGREEMENT

THIS AGREEMENT made this 1st day of September in the year Two Thousand and Twenty-One between **SPEEDWAY SAND & GRAVEL, INC.**, hereinafter called the Contractor, and the City of Madison, Wisconsin, hereinafter called the City.

WHEREAS, the Common Council of the said City of Madison under the provisions of a resolution adopted **AUGUST 31, 2021**, and by virtue of authority vested in the said Council, has awarded to the Contractor the work of performing certain construction.

NOW, THEREFORE, the Contractor and the City, for the consideration hereinafter named, agree as follows:

1. **Scope of Work.** The Contractor shall, perform the construction, execution and completion of the following listed complete work or improvement in full compliance with the Plans, Specifications, Standard Specifications, Supplemental Specifications, Special Provisions and contract; perform all items of work covered or stipulated in the proposal; perform all altered or extra work; and shall furnish, unless otherwise provided in the contract, all materials, implements, machinery, equipment, tools, supplies, transportation, and labor necessary to the prosecution and completion of the work or improvements:

### SUMMIT MAINTENANCE FACILITY IMPROVEMENTS 2021 CONTRACT NO. 9055

2. **Completion Date/Contract Time.** Construction work must begin within seven (7) calendar days after the date appearing on mailed written notice to do so shall have been sent to the Contractor and shall be carried on at a rate so as to secure full completion SEE SPECIAL PROVISIONS, the rate of progress and the time of completion being essential conditions of this Agreement.
3. **Contract Price.** The City shall pay to the Contractor at the times, in the manner and on the conditions set forth in said specifications, the sum of **ONE HUNDRED ELEVEN THOUSAND FIVE HUNDRED THIRTY-FOUR AND 89/100 (\$111,534.89)** Dollars being the amount bid by such Contractor and which was awarded to him/her as provided by law.
4. **Affirmative Action.** In the performance of the services under this Agreement the Contractor agrees not to discriminate against any employee or applicant because of race, religion, marital status, age, color, sex, disability, national origin or ancestry, income level or source of income, arrest record or conviction record, less than honorable discharge, physical appearance, sexual orientation, gender identity, political beliefs, or student status. The Contractor further agrees not to discriminate against any subcontractor or person who offers to subcontract on this contract because of race, religion, color, age, disability, sex, sexual orientation, gender identity or national origin.

The Contractor agrees that within thirty (30) days after the effective date of this agreement, the Contractor will provide to the City Affirmative Action Division certain workforce utilization statistics, using a form to be furnished by the City.

If the contract is still in effect, or if the City enters into a new agreement with the Contractor, within one year after the date on which the form was required to be provided, the Contractor will provide updated workforce information using a second form, also to be furnished by the City. The second form will be submitted to the City Affirmative Action Division no later than one year after the date on which the first form was required to be provided.

The Contractor further agrees that, for at least twelve (12) months after the effective date of this contract, it will notify the City Affirmative Action Division of each of its job openings at facilities in Dane County for which applicants not already employees of the Contractor are to be considered. The notice will include a job description, classification, qualifications and application procedures



and deadlines. The Contractor agrees to interview and consider candidates referred by the Affirmative Action Division if the candidate meets the minimum qualification standards established by the Contractor, and if the referral is timely. A referral is timely if it is received by the Contractor on or before the date started in the notice.

Articles of Agreement  
Article I

The Contractor shall take affirmative action in accordance with the provisions of this contract to insure that applicants are employed, and that employees are treated during employment without regard to race, religion, color, age, marital status, disability, sex, sexual orientation, gender identity or national origin and that the employer shall provide harassment free work environment for the realization of the potential of each employee. Such action shall include, but not be limited to, the following: employment, upgrading, demotion or transfer, recruitment or recruitment advertising, layoff or termination, rates of pay or other forms of compensation and selection for training including apprenticeship insofar as it is within the control of the Contractor. The Contractor agrees to post in conspicuous places available to employees and applicants notices to be provided by the City setting out the provisions of the nondiscrimination clauses in this contract.

Article II

The Contractor shall in all solicitations or advertisements for employees placed by or on behalf of the Contractors state that all qualified or qualifiable applicants will be employed without regard to race, religion, color, age, marital status, disability, sex, sexual orientation, gender identity or national origin.

Article III

The Contractor shall send to each labor union or representative of workers with which it has a collective bargaining agreement or other contract or understanding a notice to be provided by the City advising the labor union or worker's representative of the Contractor's equal employment opportunity and affirmative action commitments. Such notices shall be posted in conspicuous places available to employees and applicants for employment.

Article V

The Contractor agrees that it will comply with all provisions of the Affirmative Action Ordinance of the City of Madison, including the contract compliance requirements. The Contractor agrees to submit the model affirmative action plan for public works contractors in a form approved by the Affirmative Action Division Manager.

Article VI

The Contractor will maintain records as required by Section 39.02(9)(f) of the Madison General Ordinances and will provide the City Affirmative Action Division with access to such records and to persons who have relevant and necessary information, as provided in Section 39.02(9)(f). The City agrees to keep all such records confidential, except to the extent that public inspection is required by law.

Article VII

In the event of the Contractor's or subcontractor's failure to comply with the Equal Employment Opportunity and Affirmative Action Provisions of this contract or Section 39.03 and 39.02 of the Madison General Ordinances, it is agreed that the City at its option may do any or all of the following:

1. Cancel, terminate or suspend this Contract in whole or in part.

2. Declare the Contractor ineligible for further City contracts until the Affirmative Action requirements are met.
3. Recover on behalf of the City from the prime Contractor 0.5 percent of the contract award price for each week that such party fails or refuses to comply, in the nature of liquidated damages, but not to exceed a total of five percent (5%) of the contract price, or ten thousand dollars (\$10,000), whichever is less. Under public works contracts, if a subcontractor is in noncompliance, the City may recover liquidated damages from the prime Contractor in the manner described above. The preceding sentence shall not be construed to prohibit a prime Contractor from recovering the amount of such damage from the non-complying subcontractor.

#### Article VIII

The Contractor shall include the above provisions of this contract in every subcontract so that such provisions will be binding upon each subcontractor. The Contractor shall take such action with respect to any subcontractor as necessary to enforce such provisions, including sanctions provided for noncompliance.

#### Article IX

The Contractor shall allow the maximum feasible opportunity to small business enterprises to compete for any subcontracts entered into pursuant to this contract. (In federally funded contracts the terms "DBE, MBE and WBE" shall be substituted for the term "small business" in this Article.)

5. **Substance Abuse Prevention Program Required.** Prior to commencing work on the Contract, the Contractor, and any Subcontractor, shall have in place a written program for the prevention of substance abuse among its employees as required under Wis. Stat. Sec. 103.503.
6. **Contractor Hiring Practices.**

#### **Ban the Box - Arrest and Criminal Background Checks. (Sec. 39.08, MGO)**

This provision applies to all prime contractors on contracts entered into on or after January 1, 2016, and all subcontractors who are required to meet prequalification requirements under MGO 33.07(7)(I), MGO as of the first time they seek or renew pre-qualification status on or after January 1, 2016. The City will monitor compliance of subcontractors through the pre-qualification process.

- a. **Definitions.** For purposes of this section, "Arrest and Conviction Record" includes, but is not limited to, information indicating that a person has been questioned, apprehended, taken into custody or detention, held for investigation, arrested, charged with, indicted or tried for any felony, misdemeanor or other offense pursuant to any law enforcement or military authority.

"Conviction record" includes, but is not limited to, information indicating that a person has been convicted of a felony, misdemeanor or other offense, placed on probation, fined, imprisoned or paroled pursuant to any law enforcement or military authority.

"Background Check" means the process of checking an applicant's arrest and conviction record, through any means.

- b. **Requirements.** For the duration of this Contract, the Contractor shall:
  1. Remove from all job application forms any questions, check boxes, or other inquiries regarding an applicant's arrest and conviction record, as defined herein.

2. Refrain from asking an applicant in any manner about their arrest or conviction record until after conditional offer of employment is made to the applicant in question.
3. Refrain from conducting a formal or informal background check or making any other inquiry using any privately or publicly available means of obtaining the arrest or conviction record of an applicant until after a conditional offer of employment is made to the applicant in question.
4. Make information about this ordinance available to applicants and existing employees, and post notices in prominent locations at the workplace with information about the ordinance and complaint procedure using language provided by the City.
5. Comply with all other provisions of Sec. 39.08, MGO.

**c. Exemptions:** This section shall not apply when:



1. Hiring for a position where certain convictions or violations are a bar to employment in that position under applicable law, or
2. Hiring a position for which information about criminal or arrest record, or a background check is required by law to be performed at a time or in a manner that would otherwise be prohibited by this ordinance, including a licensed trade or profession where the licensing authority explicitly authorizes or requires the inquiry in question.

To be exempt, Contractor has the burden of demonstrating that there is an applicable law or regulation that requires the hiring practice in question, if so, the contractor is exempt from all of the requirements of this ordinance for the position(s) in question.

**SUMMIT MAINTENANCE FACILITY IMPROVEMENTS 2021  
CONTRACT NO. 9055**

IN WITNESS WHEREOF, the Contractor has hereunto set his/her hand and seal and the City has caused this contract to be sealed with its corporate seal and to be executed by its Mayor and City Clerk on the dates written below.

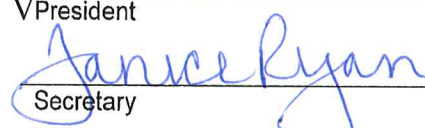

Countersigned:

	9/1/21
Witness	Date
	9/1/21
Witness	Date

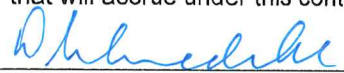

<u>SPEEDWAY SAND &amp; GRAVEL, INC.</u>	
Company Name	
	9/1/21
V President	Date
	9/1/21
Secretary	Date

CITY OF MADISON, WISCONSIN

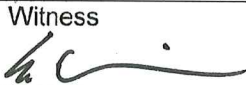
Provisions have been made to pay the liability that will accrue under this contract.

	9/9/2021
Finance Director	Date
	9/9/2021
Witness	Date
	9-8-21
Witness	Date

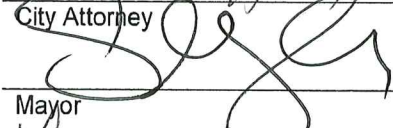
Approved as to form:

	9/9/21
City Attorney	Date
	9/9/21
Mayor	Date
	9/8/21
City Clerk	Date

**SECTION I: PAYMENT AND PERFORMANCE BOND**

LET ALL KNOW BY THESE DOCUMENTS PRESENTED, that we **SPEEDWAY SAND & GRAVEL, INC.** as principal, and **Fidelity and Deposit Company of Maryland** Company of **Schaumburg, IL** as surety, are held and firmly bound unto the City of Madison, Wisconsin, in the sum of **ONE HUNDRED ELEVEN THOUSAND FIVE HUNDRED THIRTY-FOUR AND 89/100 (\$111,534.89)** Dollars, lawful money of the United States, for the payment of which sum to the City of Madison, we hereby bind ourselves and our respective executors and administrators firmly by these presents.

The condition of this Bond is such that if the above bounden shall on his/her part fully and faithfully perform all of the terms of the Contract entered into between him/herself and the City of Madison for the construction of:

**SUMMIT MAINTENANCE FACILITY IMPROVEMENTS 2021  
CONTRACT NO. 9055**

in Madison, Wisconsin, and shall pay all claims for labor performed and material furnished in the prosecution of said work, and save the City harmless from all claims for damages because of negligence in the prosecution of said work, and shall save harmless the said City from all claims for compensation (under Chapter 102, Wisconsin Statutes) of employees and employees of subcontractor, then this Bond is to be void, otherwise of full force, virtue and effect.

Signed and sealed this 1st day of September, 2021

Countersigned:

**SPEEDWAY SAND & GRAVEL, INC.**

Company Name (Principal)

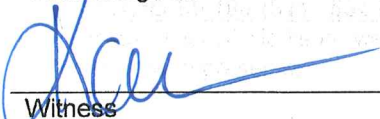
  
Witness

  
V. President N/A Seal

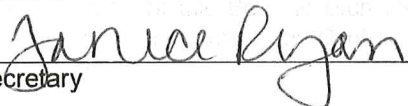
  
Secretary

Approved as to form:

**Fidelity and Deposit Company of Maryland**

Surety Seal

Salary Employee  Commission

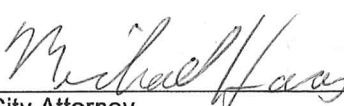
  
City Attorney

By   
Attorney-in-Fact, **Nicole Stillings**

This certifies that I have been duly licensed as an agent for the above company in Wisconsin under National Producer Number **6966174** for the year **2021**, and appointed as attorney-in-fact with authority to execute this payment and performance bond which power of attorney has not been revoked.

September 1, 2021  
Date

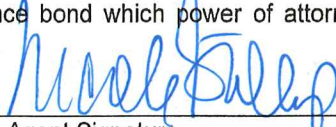
  
Agent Signature

**ZURICH AMERICAN INSURANCE COMPANY  
COLONIAL AMERICAN CASUALTY AND SURETY COMPANY  
FIDELITY AND DEPOSIT COMPANY OF MARYLAND  
POWER OF ATTORNEY**

KNOW ALL MEN BY THESE PRESENTS: That the ZURICH AMERICAN INSURANCE COMPANY, a corporation of the State of New York, the COLONIAL AMERICAN CASUALTY AND SURETY COMPANY, a corporation of the State of Illinois, and the FIDELITY AND DEPOSIT COMPANY OF MARYLAND a corporation of the State of Maryland (herein collectively called the "Companies"), by **Robert D. Murray, Vice President**, in pursuance of authority granted by Article V, Section 8, of the By-Laws of said Companies, which are set forth on the reverse side hereof and are hereby certified to be in full force and effect on the date hereof, do hereby nominate, constitute, and appoint **Melinda C. BLODGETT, Colby D. WHITE, Jerome T. OUMET, Nicole STILLINGS, Joshua R. LOFTIS, Ted JORGENSEN, R. C. BOWMAN, Brian J. OESTREICH and Nathan WEAVER, all of Minneapolis, Minnesota**, its true and lawful agent and Attorney-in-Fact, to make, execute, seal and deliver, for, and on its behalf as surety, and as its act and deed: **any and all bonds and undertakings**, and the execution of such bonds or undertakings in pursuance of these presents, shall be as binding upon said Companies, as fully and amply, to all intents and purposes, as if they had been duly executed and acknowledged by the regularly elected officers of the ZURICH AMERICAN INSURANCE COMPANY at its office in New York, New York., the regularly elected officers of the COLONIAL AMERICAN CASUALTY AND SURETY COMPANY at its office in Owings Mills, Maryland., and the regularly elected officers of the FIDELITY AND DEPOSIT COMPANY OF MARYLAND at its office in Owings Mills, Maryland., in their own proper persons.

The said Vice President does hereby certify that the extract set forth on the reverse side hereof is a true copy of Article V, Section 8, of the By-Laws of said Companies, and is now in force.

IN WITNESS WHEREOF, the said Vice-President has hereunto subscribed his/her names and affixed the Corporate Seals of the said **ZURICH AMERICAN INSURANCE COMPANY, COLONIAL AMERICAN CASUALTY AND SURETY COMPANY, and FIDELITY AND DEPOSIT COMPANY OF MARYLAND**, this 9th day of June, A.D. 2021.



**ATTEST:**  
**ZURICH AMERICAN INSURANCE COMPANY  
COLONIAL AMERICAN CASUALTY AND SURETY COMPANY  
FIDELITY AND DEPOSIT COMPANY OF MARYLAND**

By: *Robert D. Murray*  
Vice President

By: *Dawn E. Brown*  
Secretary

**State of Maryland  
County of Baltimore**

On this 9th day of June, A.D. 2021, before the subscriber, a Notary Public of the State of Maryland, duly commissioned and qualified, **Robert D. Murray, Vice President and Dawn E. Brown, Secretary** of the Companies, to me personally known to be the individuals and officers described in and who executed the preceding instrument, and acknowledged the execution of same, and being by me duly sworn, deposed and saith, that he/she is the said officer of the Company aforesaid, and that the seals affixed to the preceding instrument are the Corporate Seals of said Companies, and that the said Corporate Seals and the signature as such officer were duly affixed and subscribed to the said instrument by the authority and direction of the said Corporations.

IN TESTIMONY WHEREOF, I have hereunto set my hand and affixed my Official Seal the day and year first above written.



Constance A. Dunn, Notary Public  
My Commission Expires: July 9, 2023

**Authenticity of this bond can be confirmed at [bondvalidator.zurichna.com](http://bondvalidator.zurichna.com) or 410-559-8790**

**EXTRACT FROM BY-LAWS OF THE COMPANIES**

"Article V, Section 8, Attorneys-in-Fact. The Chief Executive Officer, the President, or any Executive Vice President or Vice President may, by written instrument under the attested corporate seal, appoint attorneys-in-fact with authority to execute bonds, policies, recognizances, stipulations, undertakings, or other like instruments on behalf of the Company, and may authorize any officer or any such attorney-in-fact to affix the corporate seal thereto; and may with or without cause modify or revoke any such appointment or authority at any time."

**CERTIFICATE**

I, the undersigned, Vice President of the ZURICH AMERICAN INSURANCE COMPANY, the COLONIAL AMERICAN CASUALTY AND SURETY COMPANY, and the FIDELITY AND DEPOSIT COMPANY OF MARYLAND, do hereby certify that the foregoing Power of Attorney is still in full force and effect on the date of this certificate; and I do further certify that Article V, Section 8, of the By-Laws of the Companies is still in force.

This Power of Attorney and Certificate may be signed by facsimile under and by authority of the following resolution of the Board of Directors of the ZURICH AMERICAN INSURANCE COMPANY at a meeting duly called and held on the 15th day of December 1998.

RESOLVED: "That the signature of the President or a Vice President and the attesting signature of a Secretary or an Assistant Secretary and the Seal of the Company may be affixed by facsimile on any Power of Attorney...Any such Power or any certificate thereof bearing such facsimile signature and seal shall be valid and binding on the Company."

This Power of Attorney and Certificate may be signed by facsimile under and by authority of the following resolution of the Board of Directors of the COLONIAL AMERICAN CASUALTY AND SURETY COMPANY at a meeting duly called and held on the 5th day of May, 1994, and the following resolution of the Board of Directors of the FIDELITY AND DEPOSIT COMPANY OF MARYLAND at a meeting duly called and held on the 10th day of May, 1990.

RESOLVED: "That the facsimile or mechanically reproduced seal of the company and facsimile or mechanically reproduced signature of any Vice-President, Secretary, or Assistant Secretary of the Company, whether made heretofore or hereafter, wherever appearing upon a certified copy of any power of attorney issued by the Company, shall be valid and binding upon the Company with the same force and effect as though manually affixed.

IN TESTIMONY WHEREOF, I have hereunto subscribed my name and affixed the corporate seals of the said Companies, this 1st day of September, 2021.



*Brian M. Hodges*

By: Brian M. Hodges  
Vice President

**TO REPORT A CLAIM WITH REGARD TO A SURETY BOND, PLEASE SUBMIT A COMPLETE DESCRIPTION OF THE CLAIM INCLUDING THE PRINCIPAL ON THE BOND, THE BOND NUMBER, AND YOUR CONTACT INFORMATION TO:**

Zurich Surety Claims  
1299 Zurich Way  
Schaumburg, IL 60196-1056  
[www.reportsfclaims@zurichna.com](mailto:www.reportsfclaims@zurichna.com)  
800-626-4577

**Authenticity of this bond can be confirmed at [bondvalidator.zurichna.com](http://bondvalidator.zurichna.com) or 410-559-8790**